



VALVE REGULATED LEAD-ACID BATTERY FOR START-STOP

H4-50-L-T2-A



LONGWAY brand AGM start-stop series battery are specially designed for vehicle start/stop system. Comply with IEC 60095-1/2018, VDA start-stop Battery Standard specification (AGM), GB/T12666-2016 standard. Start-stop series battery adopts rare earth alloy with patented technology, unique lead paste formula and additives to ensure the product has a longer service life, wide temperature range, low self discharge rate, Strong storage performance and other advantages. Meanwhile they are valve regulated sealed design, which belongs to non-spillable, reliable and maintenance-free environmental friendly products. It complies with EU battery directive RoHS & REACH.

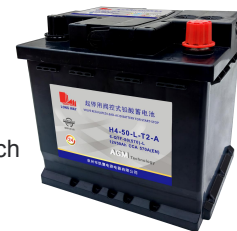

Performance

Nominal Voltage	12V
Rated capacity	50Ah@20Hr to 10.50V@25°C
Reserve Capacity	80min@25°C
CCA (-18°C)	570A
Weight	Approx. (15.4±2%) kg
Internal resistance	Approx. 3.70mΩ, full charged@25°C
Operating Temperature	-30°C~70°C
Charging Voltage	14.5~15.0V@25°C
Base Hold-down	B13
Terminal	1 (EN standard)

Dimensions: L206*W175*H189(TH189)mm

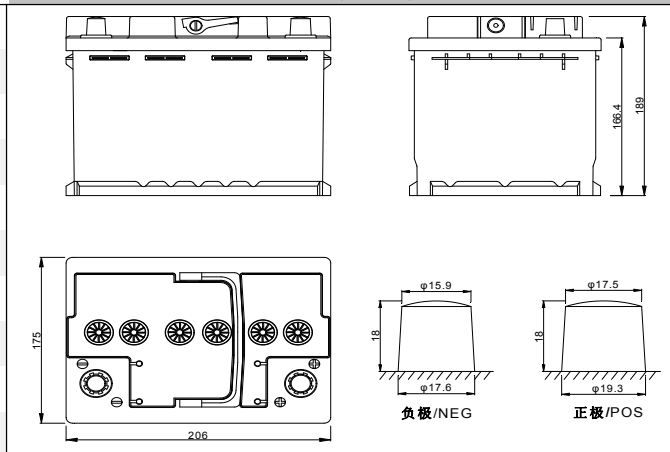

Cycles with 17.5% Depth of Discharge

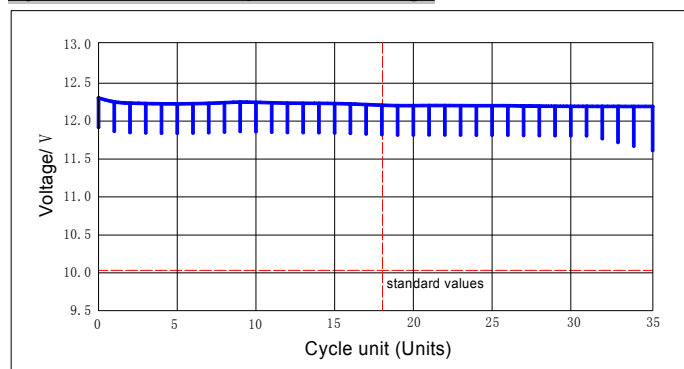

Cycles with 50% Depth of Discharge

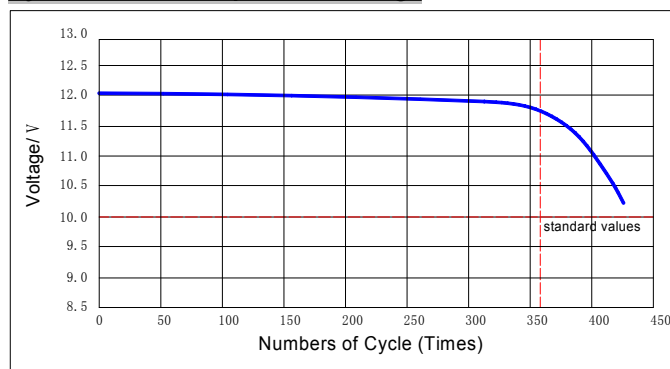

Ability of start-stop cycling

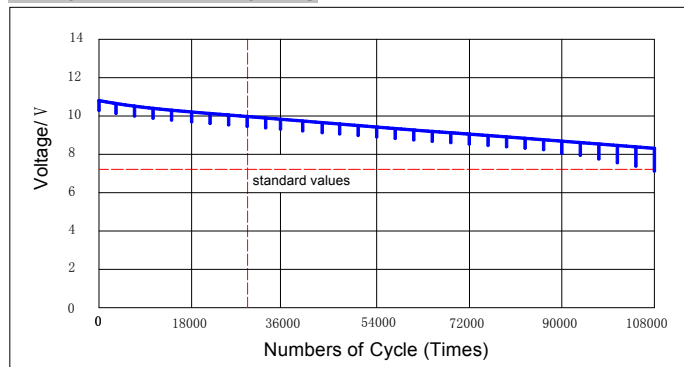

Capacity Retention Characteristic

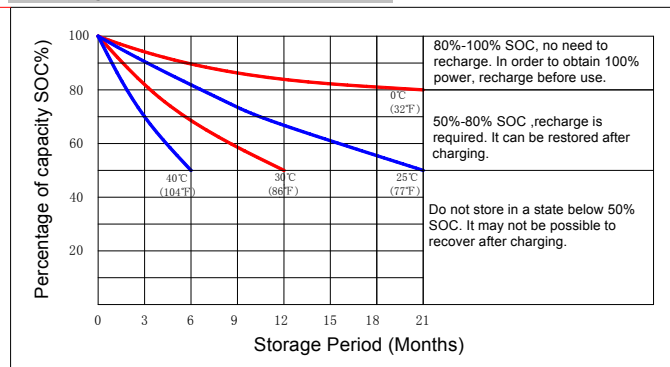

Kaiying Power Supply & Electrical Equip Co., Ltd

Add: Laogang Industrial area, Chengxiang Town, Anxi County, Fujian, China

Tel: 0595-68782266 Fax: 0595-68782222

Website: <http://www.longwaybattery.com> Email: sales@longwaybattery.com

KY-IOP-6-QTF-50 A0. December 2022

Note: This information generally describes use only and is not intended to represent any warranty or promise regarding the battery. Battery specifications and battery design are subject to change without notice. Contact LONGWAY Batteries for the latest information.